



Gary Stamberger – Training Director
Magnaflow Exhaust Products

On Board Diagnostics Part II



As promised from last month, more on OBD. Refer to our Website, Magnaflow.com for archived Bulletins.
(<http://www.magnaflow.com/07techtips/techbulletins.asp>)

Data Stream

Referred to as Current Data or Live Data, this information is available to the technician using a Scan Tool. The number of PIDS (Parameter Identification) available at any given time will depend on a couple of different factors. The particular vehicle (Manufacturer) involved will have the greatest influence on the amount of data available. Followed by the type of Scan Tool used and whether you are viewing the data on the Global OBD II side or Manufacture Specific, aka Enhanced Mode. (Figure 1) Most Scan Tools will have options for viewing the data in different formats such as digital or graphing mode. Graphing can be particularly useful when looking at Oxygen Sensor activity. (Figure 2) The data available will consist of inputs and outputs, calculated values and system status information.

Viewing data and becoming proficient at recognizing problem areas is one of the skills we spoke of in last months Bulletin (TB-80016). Part of any training on a particular tool is the repetitive process of using it over and over until you begin to recognize when certain data doesn't look right. This process will then lead you toward a problem area where further testing will reveal the fault. You can not recognize bad data until you have looked at enough good data. One item to be aware of is the practice of substituting good data values for suspect ones. Due to something called Adaptive Strategy, when the PCM suspects that a particular input may not be reporting accurately, it will substitute a known good value for that sensor and run the vehicle on learned values. This will only show up in Enhanced Mode as Global OBD II will always display actual values. This should not deter you from viewing in Enhanced Mode. It has always been my practice to look at codes and data in both modes.

Chrysler, 2000-2008 S	Y-8, 2000	Y, Dodge, Car, Neon
Computer?		
ENGINE/PCM	GLOBAL OBDII	
ABS	AIRBAG	
SKIM SECURITY	CLUSTER CONTROL	

FIGURE 1

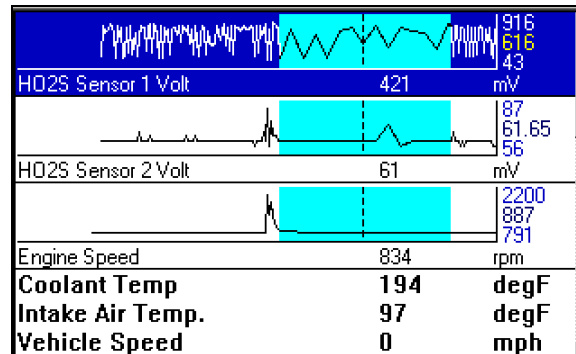

FIGURE 2

Freeze Frame

Freeze frame is a "snap shot" of data taken when a code is set. This can be very valuable information as it allows the technician an opportunity to duplicate the conditions under which the trouble code was recorded. The number of freeze frame events recorded and viewable by the technician will again depend on the vehicle and scan tool being used. Early systems could only store one batch of information, if more than one code was recorded we would typically only be able to view the Freeze Frame for the last code set. Changes in both OBD and Scan Tool technology have allowed us to have multiple sets of information available for multiple codes set. One exception is that of Misfire. Misfire codes and subsequent data take precedent and will overwrite any previous freeze data stored. Be aware that all freeze frame information is lost when codes are cleared.





FIGURE 3

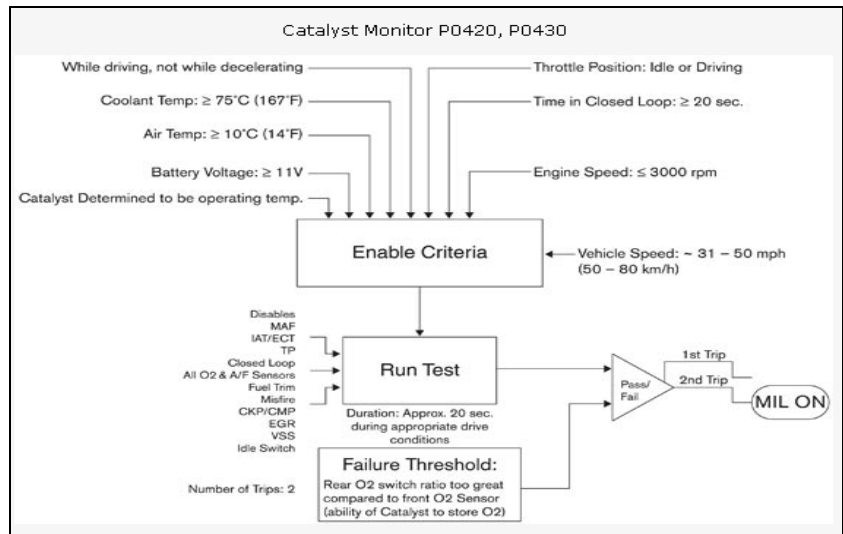

FIGURE 4 Courtesy Toyota

Monitors

Monitors, also referred to as Readiness Indicators are considered the single most comprehensive change that came with OBD II. CARB and the EPA recognized that a vehicle started polluting long before the PCM recognized a fault, set a code and illuminated the MIL. Early OBD systems did not have the capability to recognize degradation of components or systems. Today's OBD II system is designed to recognize when a vehicle could potentially exceed its designed emission standard by a factor of 1.5. It does this through a series of system Monitors.

During normal operation the PCM will conduct certain tests to gauge the operational health of a particular system or component. The Monitors operate in two categories, Continuous and Non-Continuous. As you can probably guess the Continuous Monitors run, well, continuously. They are Misfire, Fuel System and Comprehensive Component. Non-Continuous consist of Catalyst, Evaporative, Oxygen Sensor, Oxygen Sensor Heater, EGR Monitor and more. These require a very specific Drive Cycle (**Figure 4**) that will meet all the criteria necessary for a complete test. Scan Tools will have a Monitor Status screen that indicates if the Monitors have run to completion. (**Figure 3**) Next to each component or system it will indicate "Ready" or "Not Ready", "Complete" or "Incomplete". If the vehicle is not equipped with a certain system the screen will indicate "Not Supported" or "Not Available".

When one or more indicators read Not Ready or Incomplete, it is an indication that codes have been cleared recently, either with a scan tool or loss of power to the PCM such as battery disconnect. If there is no history of either of these events occurring this is an indication of the PCM intermittently losing power or it is rebooting which could be an internal problem. It is commonly known that the Catalyst and Evaporative System Monitors are the hardest to run to completion.

Many states have moved to an OBD system test for Emission Testing in place of tail pipe testing for vehicles 1996 and newer. California is considering this transition as we move into 2010 (No date has been set for implementation). The test includes checking for proper location of DLC (Data Link Connector), bulb check of MIL, no MIL when vehicle is running, no codes in system and all the Monitors have run to completion. Monitors are a key component because they are a direct indication of whether the OBD system had been tampered with prior to Inspection.

The USEPA and CARB authorities have generally found that OBD II systems are more effective in detecting emission-related malfunctions on in-use vehicles compared to existing Inspection and Maintenance (I/M) tailpipe testing procedures. Current Smog Check data indicates that vehicles are more likely to fail an OBD II-based inspection than the required tailpipe emissions test. With the reduced testing times (10 mins. for OBD vs. 20 mins. for tail pipe) and cost savings in equipment it's not beyond the realm of possibility that states currently having none or minimal Inspection Programs may consider adopting an OBD Emissions Testing program. These programs have proven to create a healthy environment and also a healthy bottom line for repair shops.

Cleaning up the environment...one converter at a time

Gary

TUNER TOOLS
THE INSIDE LINE

800-990-0905



WWW.MAGNAFLOW.COM